

# チューンド・マス・ダンパー(TMD)

## ◆TMD制振模型の設計

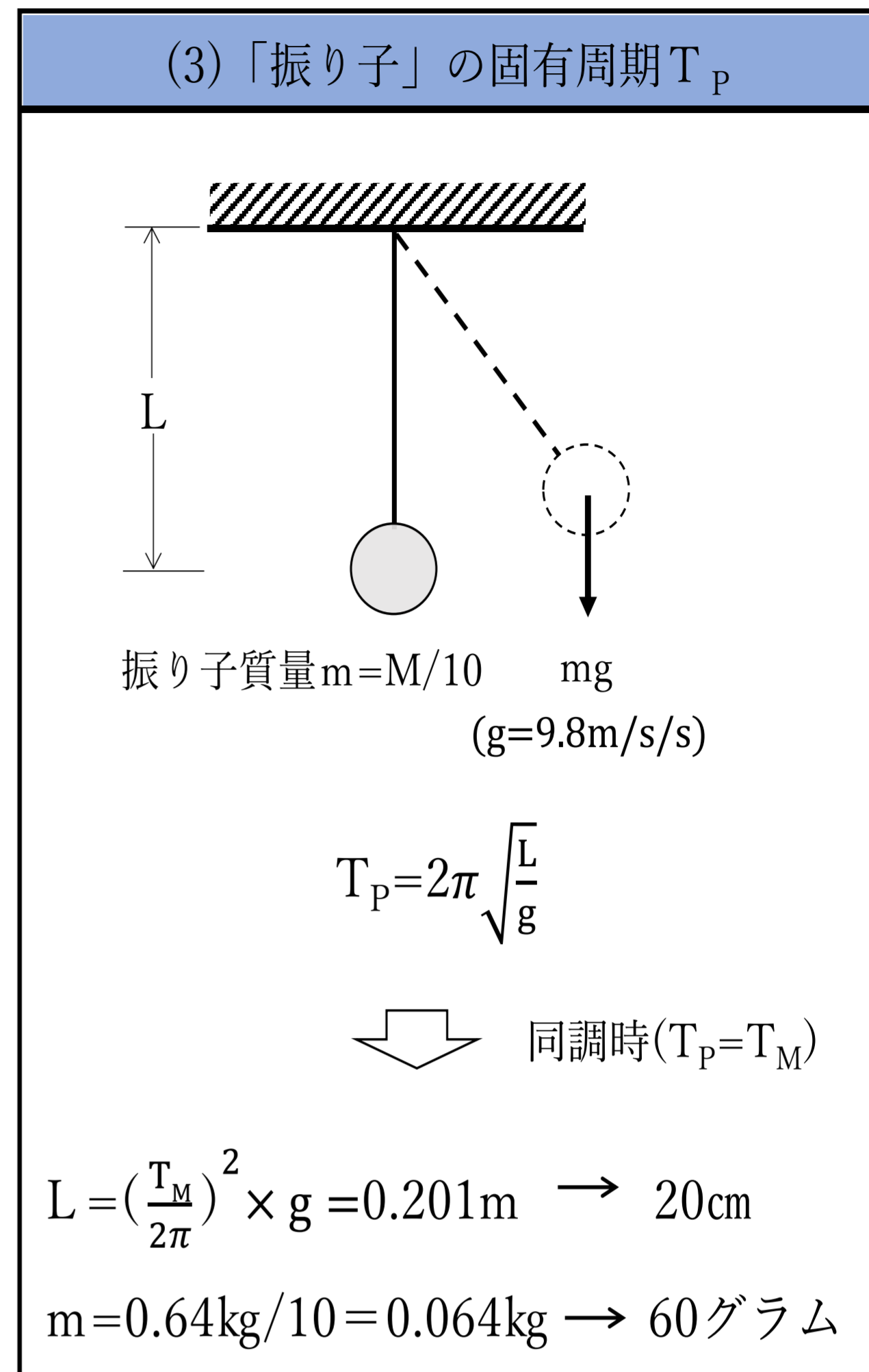

## ◆TMD制振模型の制作

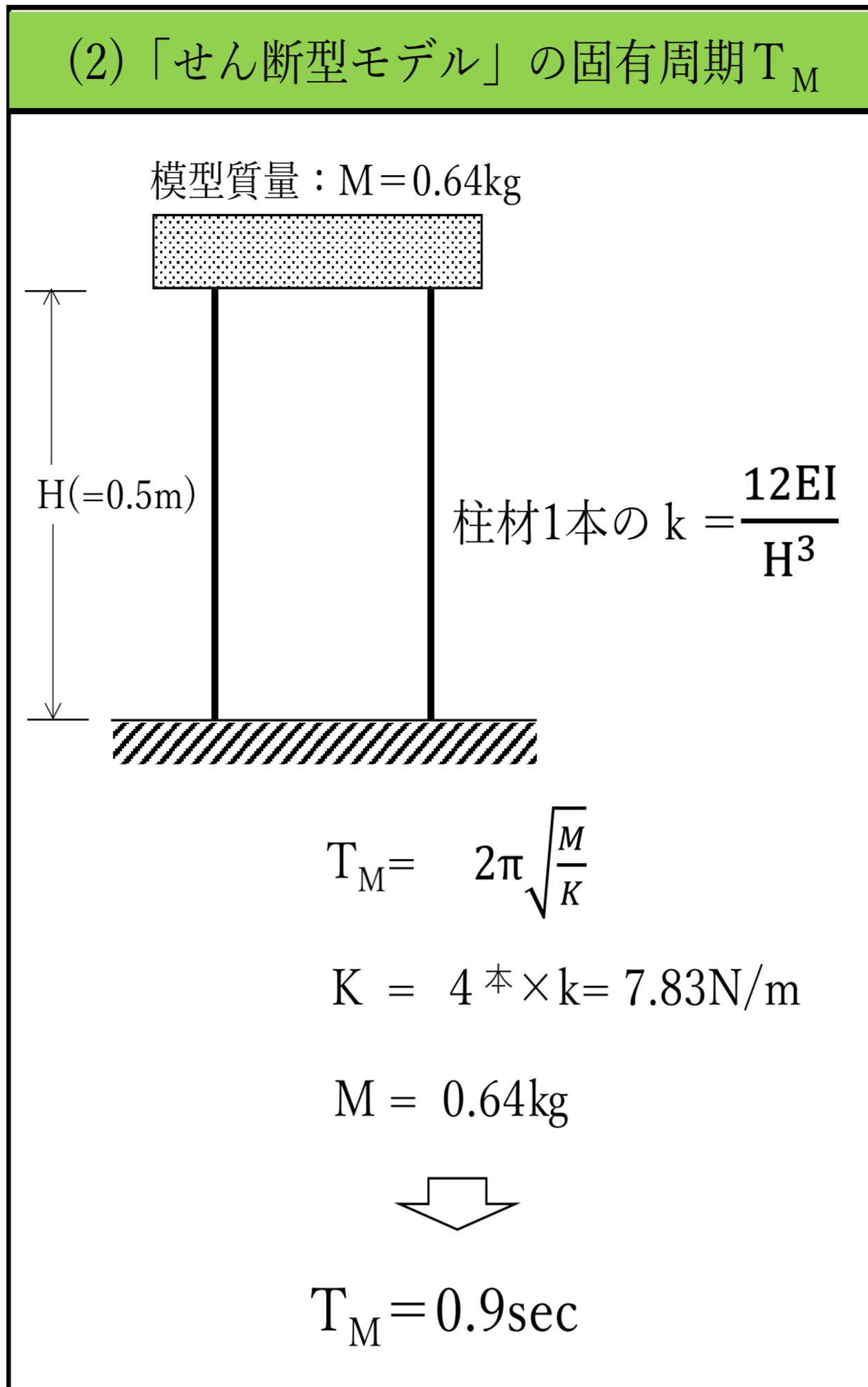
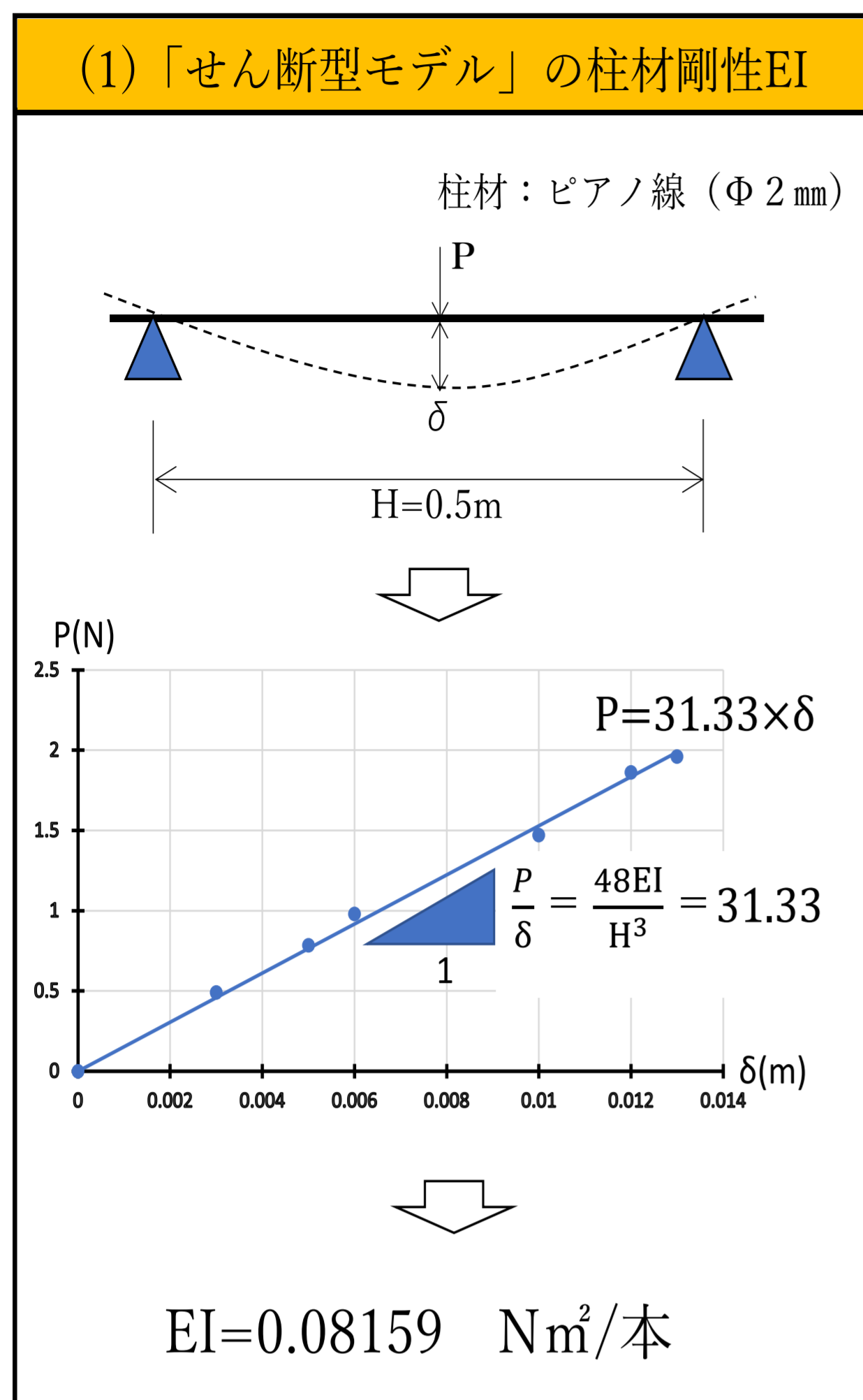
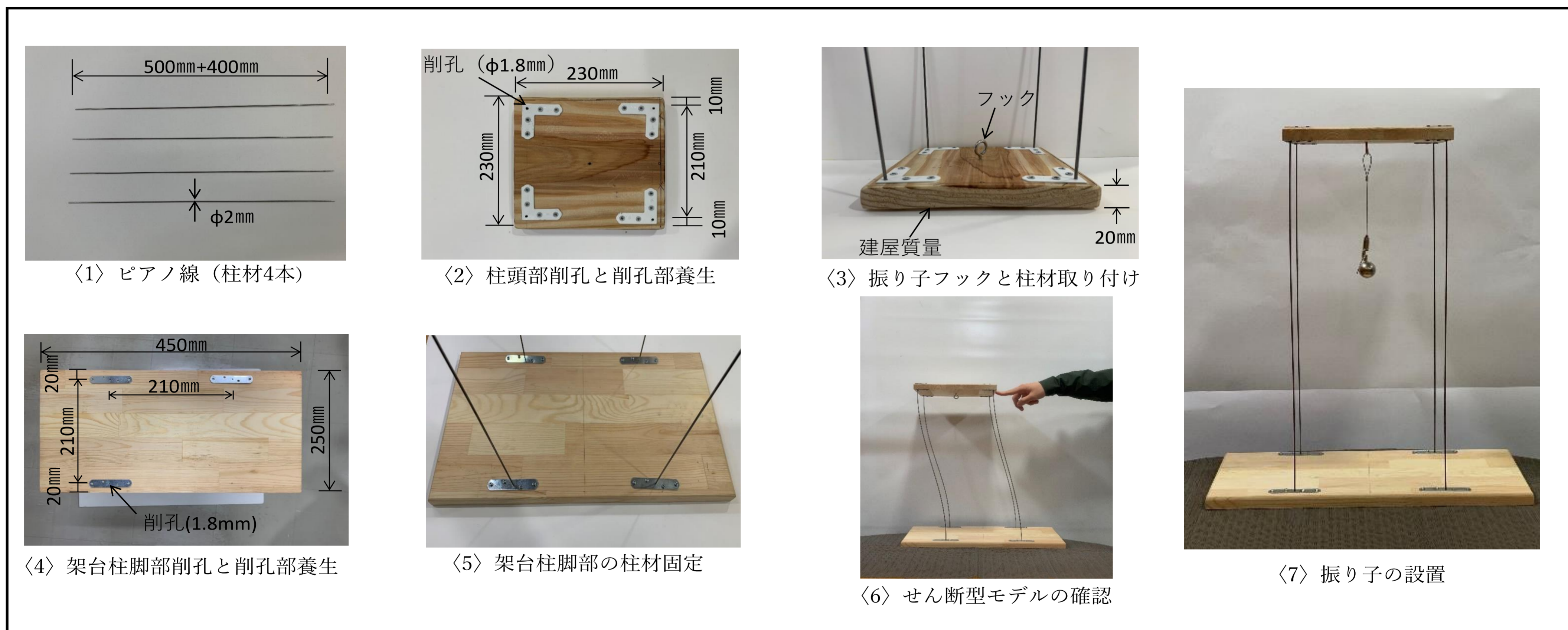

## ◆TMD制振効果の実験

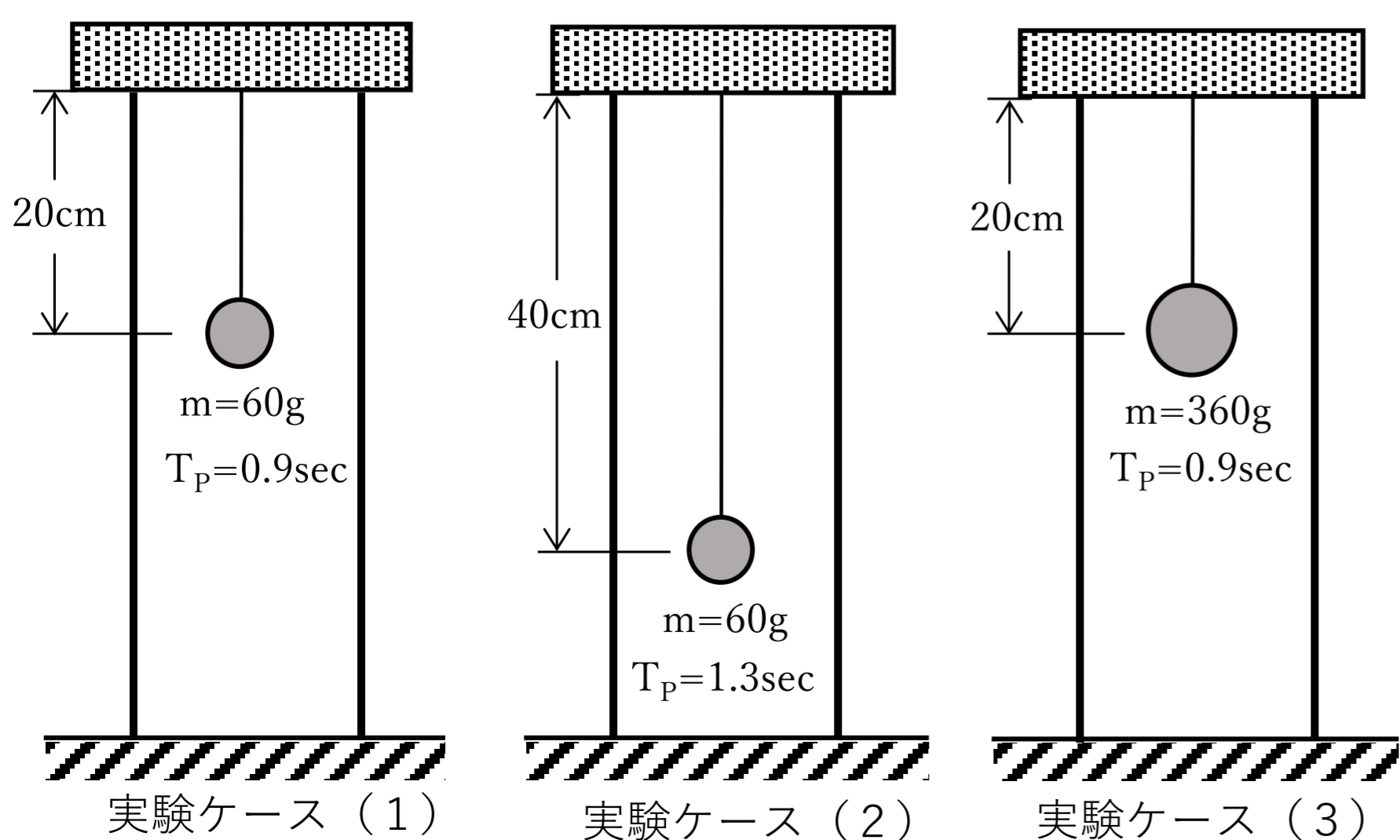

## ◆TMDの原理とブランコの制動

